

# Specification Sheet | 795 nm Series

Single Angle Facet (SAF) Gain Chip

## Description

The 795 nm SAF Series of high-performance edge-emitting gain chips are based on Photodigm’s advanced monolithic Gallium Arsenide (GaAs) based laser technology. It provides a single spatial mode beam, a unique anti-reflective and highly reflective coating pair (>90% HR, <0.1% AR), and has passivated facets for reliability. The 795 nm Series SAF gain chip devices have a curved waveguide forming a 5° angle exit at the facet and are frequently used in applications involving external-cavity diode lasers (ECDLs).

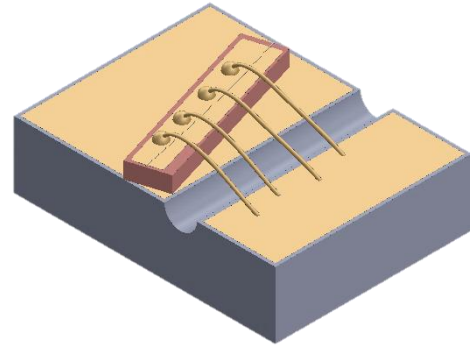

## 795 nm SAF Gain Chip Characteristics

Parameters <sup>1</sup>	Chip Architecture
	SAF
Wavelength, Nominal (nm)	795 ± 5
Output Power, Max (mW) <sup>2</sup>	100
Operating Current, Max (CW & Pulsed) (mA)	250
Optical Bandwidth at 3 dB, Nominal (nm)	18

1. Characteristics at T<sub>c</sub> = 25 °C unless otherwise specified. Operating outside of these parameters voids warranty
2. Power output is highly dependent on customer configuration of external cavity

## Specifications

Parameter	Unit	Min	Typical	Max
Storage Temperature	°C	0	-	70
Operating Temperature at SAF chip	°C	5	-	45
SAF Series Resistance	Ω	-	1.1	-
SAF Forward Voltage @ LIV Current	V	-	2	-
Beam Divergence @ FWHM (θ <sub>  </sub> x θ <sub>⊥</sub> )	°	-	6 x 28	8 x 32
SAF Preferred Polarization	TE			
Mode Structure	Fundamental Mode			
Temperature Tuning Rate	nm/°C	-	0.3	-
SAF Reverse Voltage	V	-	-	0

### Handling Precautions

These devices are sensitive to ESD. When handling the module, grounded work area and wrist strap must be used. Always store in an antistatic container with all leads shorted together.



Photodigm, Inc. reserves the right to make changes in design, specifications, and other information at any time, and without prior notice. The information contained within the specification sheet is believed to be accurate. However, no responsibility is assumed for possible inaccuracy or omission. Any information contained herein shall not legally bind Photodigm, Inc. unless it is specifically incorporated in the terms and conditions of a sales agreement.

# Specification Sheet | 795 nm Series

## Single Angle Facet (SAF) Gain Chip

### Direct Emission Drawing:

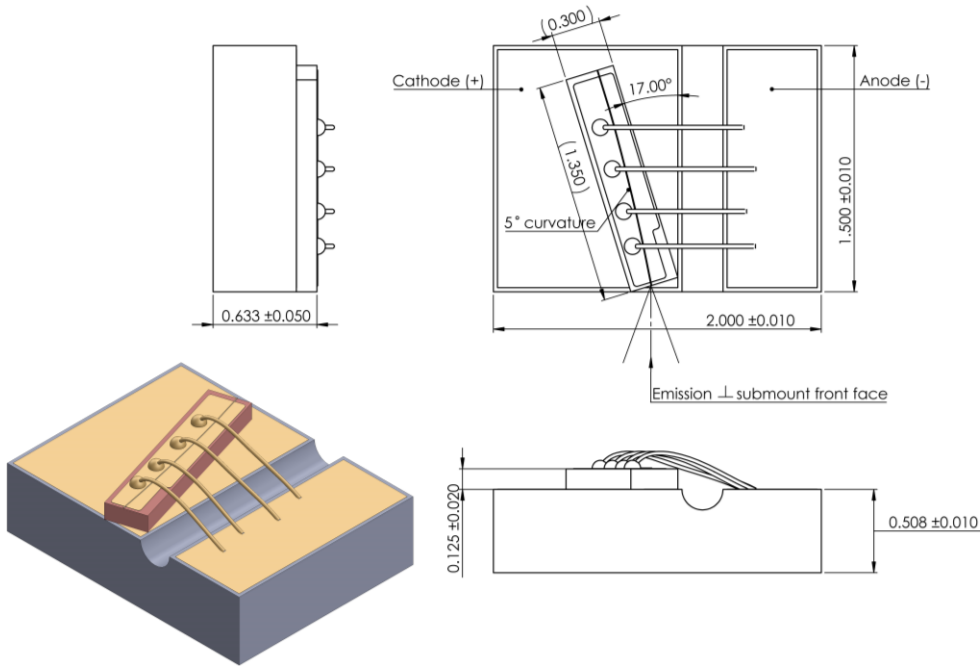

### Angled Emission Drawing:

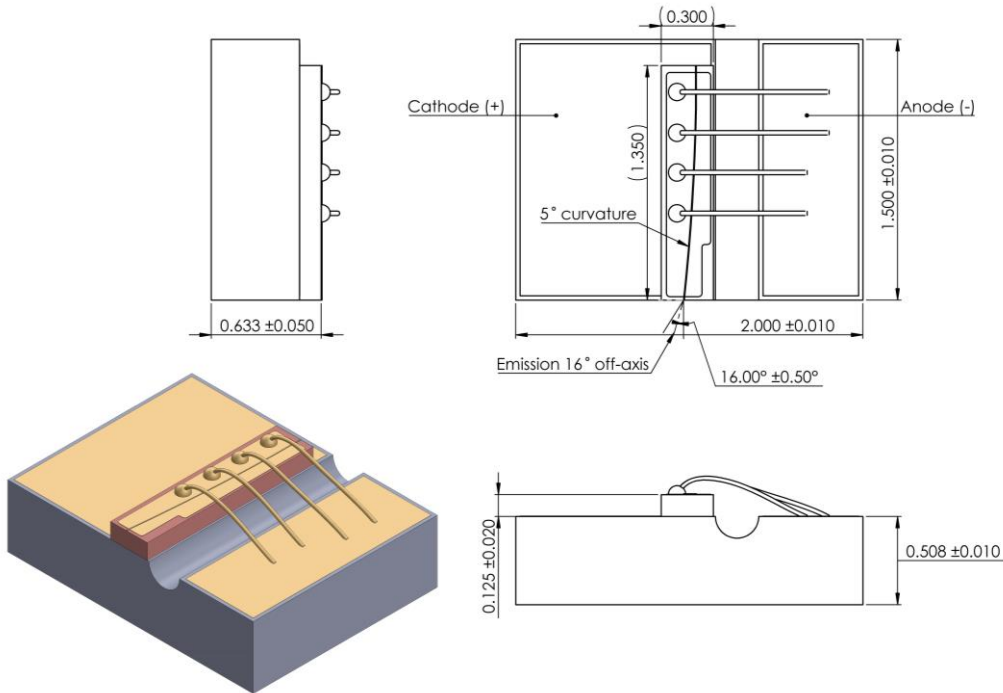

**Specification Sheet | 795 nm Series**

Single Angle Facet (SAF) Gain Chip

**LIV Characteristics with No Seed by Current**

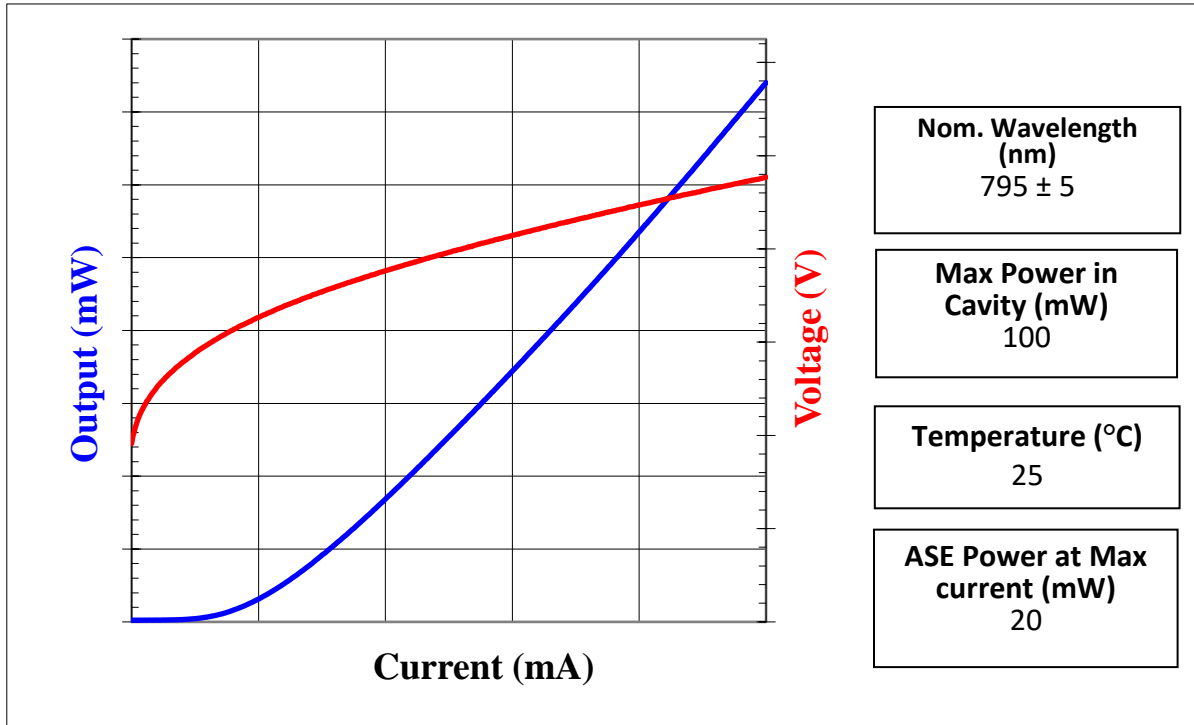

**ASE (Amplified Spontaneous Emission) Spectrum with No Seed**

